

ZHEJIANG UN FORKLIFT CO., LTD.

ADDRESS: NO.1,ROAD ONE,XINDENG NEW DISTRICT,FUYANG,
HANGZHOU,ZHEJIANG 311404,CHINA

TEL: +86-571-8688 8355 (AMERICA)

+86-571-8886 9363 (EUROPE)

+86-571-8688 8377 (ASIA, AFRICA, OCEANIA)

E-MAIL: info@unforklift.com

PARTS INQUIRY: parts@unforklift.com

www.unforklift.com



UN FORKLIFT

Li-ion
2.0-3.5 TON

**NL SERIES LITHIUM BATTERY
COUNTERBALANCE FORKLIFT**

www.unforklift.com
INNOVATIVE POWER
THE UN FORKLIFT TRUCK

NL Series Lithium Battery Counterbalance Forklift

capacity 2,000 to 3,500kg

The NL series new lithium battery forklift adopts UN internal combustion forklift's design with the strong chassis, frame, counterweight and mast. The power structure is designed to adopt UN electric forklift's concept, which use full AC system, Italy imported ZAPI controller, BMS control system and high quality lithium battery. This combination of IC forklift and electric forklift makes an ideal solution to reach customers' satisfaction on cost saving and environmental friendly.

COMFORT AND ERGONOMICS

Owing to the low center of gravity and good stability, the driver feels comfortable during turning. Bigger leg space than standard Li-ion forklifts.



DIESEL

ELECTRIC

LITHIUM BATTERY FORKLIFT IS CONVERTED FROM DIESEL FORKLIFT

TWO IN ONE, ONE FOR TWO



Large foot space



Low and Wide Step



ZAPI controller with multifunctional instrument panel



LED lights: energy saving, long life



Pedals with comfortable angle

MAIN SPECIFICATIONS (STANDARD PERFORMANCE)

General		UN				
1	Manufacturer	UN				
2	Model	FB20-YNLZ2	FB25-YNLZ2	FB30-YNLZ2	FB35-YNLZ2	
3	Power Type	Li-ion				
4	Rated Load Capacity	Q(kg)	2000	2500	3000	3500
5	Load Centre	C(mm)	500			
6	Rated Lift Height	H3(mm)	3000			
7	Free Lift Height	H2(mm)	100			
8	Fork Size (L×W×T)	mm	1070×120×40	1070×125×45	1070×125×50	
9	Mast Tilt Angle (F/R, α°/β°)	deg	6°/12°			
10	Fork Overhang (Wheel Center to Fork Face)	X1(mm)	479	484		
11	Rear Overhang	X2(mm)	520	595	635	
12	Ground Clearance (Bottom of Mast)	H7(mm)	130	145		
13	Length to Face of Fork (Without Fork)	L1(mm)	2660	2700	2775	
14	Overall Width	B1(mm)	1150	1225		
15	Mast Lowered Height	H1(mm)	2055	2070		
16	Mast Extended Height (With Backrest)	H4(mm)	4070	4070		
17	Overhead Guard Height	H5(mm)	2215	2235		
18	Turning Radius (Outside)	Wa(mm)	2365	2425	2500	
19	Min.Aisle width for pallets	Ast(mm)	4120	4180	4255	
20	Travel Speed (No Load)	km/h	11/12			
21	Lifting Speed (Full Load)	mm/sec	260/380	250/360		220/340
22	Lowering Speed(Full Load/No Load)	mm/sec	No Load≥300 Full Load≤600			
23	Max.Gradeability (Full Load)	%	15		12	
24	Tyre (Front x 2)	mm	7.00-12-12PR	28×9-15-12PR		
25	Tyre (Rear x 2)	mm	6.00-9-10PR	6.50-10-10PR		
26	Front Tread	B2(mm)	970	1000		
27	Rear Tread	B3(mm)	980	980		
28	Wheelbase	Y(mm)	1650	1700		
29	Total Weight	kg	3385	3605	4460	4775
30	Front Axle Weight Distribution (Full Load)	kg	4846	5494	6714	6997
31	Rear Axle Weight Distribution (Full Load)	kg	538	610	746	777
32	Front Axle Weight Distribution (No Load)	kg	1354	1442	1784	1910
33	Rear Axle Weight Distribution (No Load)	kg	2031	2163	2676	2865
34	Battery	V/Ah	80V/150AH option 220AH option 350AH	80V/175AH option 270AH option 350AH	80V/220AH option 270AH option 350AH	80V/270AH option 350AH
35	Drive Motor	KW	10			
36	Lift Motor	KW	12			
37	Operating Pressure (For Attachments)	Mpa	17.5			

Specifications and characteristics are subject to change without notice.

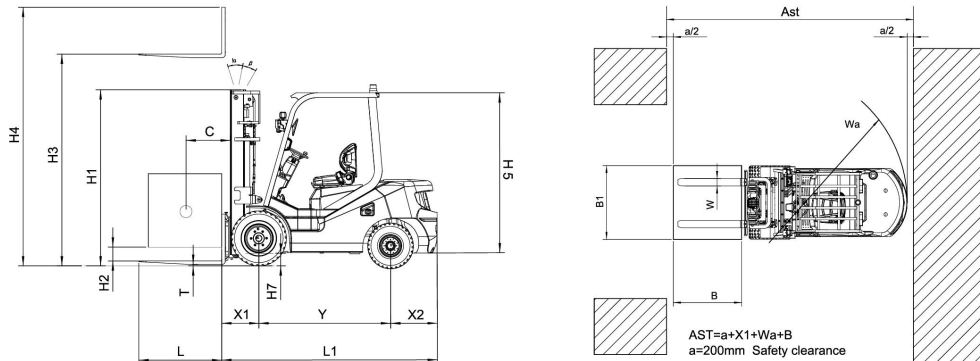

2.0-2.5 TON MAST SPECIFICATIONS & RATED CAPACITIES

Mast Type	Mast Name	Max.Fork Height (mm)	Load Capacity (KG)				Overall Height (mm)			Free Lift (mm)		Tilt Angle (Single)	Tilt Angle (Double)	Total Weight (KG)		
			FB20	FB20	FB25	FB25	Lowered	Extended	Without Backrest	With Backrest	2.0/2.5t			2.0/2.5t	FB20	FB25
			Without Backrest		With Backrest		Without Backrest		With Backrest							
Wide View Mast	M200	2000	2000	2000	2500	1550	2580	3070	100	100	6-12	3370	3870			
	M250	2500	2000	2000	2500	1800	3200	3270	100	100	6-12	3410	3910			
	M270	2700	2000	2000	2500	1900	3280	3770	140	140	6-12	3425	3725			
	M290	2900	2000	2000	2500	2005	3480	3970	140	140	6-12	3440	3940			
	M300	3000	2000	2000	2500	2000	3580	4070	140	140	6-12	3460	3760			
	M310	3100	2000	2000	2500	2105	3680	4170	140	140	6-12	3480	3980			
	M330	3300	2000	2000	2500	2205	3880	4370	140	140	6-12	3475	3775			
	M350	3500	2000	2000	2500	2300	4080	4570	140	140	6-12	3490	3790			
	M370	3700	2000	2000	2500	2405	4280	4770	140	140	6-6	3470	3810			
	M400	4000	2000	2000	2450	2605	4580	5070	140	140	6-6	3530	3830			
2-Stage Full Free View Mast	M430	4300	1800	1700	1600	2050	5150	4980	5370	140	6-6	3620	3920			
	M450	4500	1800	1800	2000	2400	2850	5080	5570	140	6-6	3570	3870			
	M470	4700	1450	1850	1750	2100	2955	5280	5770	140	6-6	3590	3890			
	M500	5000	1300	1700	1600	2050	3155	5580	6070	140	6-6	3620	3920			
	M550	5500	1100	1550	1350	1700	3405	6080	6570	140	3-6	3690	3960			
	M600	6000	960	1300	1050	1500	3655	6580	7070	140	3-6	3700	4000			
	3-Stage Full Free View Mast	FM200	2000	2000	2000	2500	1570	2508	3068	970	897	6-12	3410	3910		
		FM250	2500	2000	2000	2500	1820	3055	3518	1200	757	6-12	3450	3950		
		FM270	2700	2000	2000	2500	1920	3255	3718	1300	857	6-12	3465	3765		
		FM290	2900	2000	2000	2500	2020	3455	3918	1400	957	6-12	3480	3980		
FM300		3000	2000	2000	2500	2070	3605	4068	1470	1007	6-12	3490	3790			
FM310		3100	2000	2000	2500	2120	3755	4218	1520	1057	6-12	3500	4000			
FM330		3300	2000	2000	2500	2220	3955	4418	1620	1157	6-12	3515	3815			
FM350		3500	2000	2000	2500	2320	4105	4568	1720	1257	6-12	3530	3830			
FM370		3700	2000	2000	2500	2420	4255	4718	1800	1357	6-6	3545	3845			
FM400		4000	2000	2000	2500	2620	4608	5068	2000	1607	6-6	3570	3870			
3-Stage Full Free View Mast	TFM400	4000	1900	2300	2000	2500	1945	4907	5070	885	6-6	3600	3900			
	TFM430	4300	1850	1900	2000	2400	2045	4907	5370	1400	985	6-6	3630	3930		
	TFM450	4500	1700	1800	2000	2300	2095	5107	1480	1035	6-6	3650	3950			
	TFM470	4700	1600	1750	1900	2200	2145	5307	1548	1085	6-6	3670	3970			
	TFM500	5000	1400	1600	1500	2000	2245	5507	1648	1185	6-6	3700	4000			
	TFM525	5250	1250	1550	1350	1850	2345	5687	1748	1285	3-6	3725	4225			
	TFM550	5500	1100	1500	1200	1700	2445	5867	1800	1385	3-6	3750	4050			
	TFM600	6000	800	1400	850	1600	2645	6607	2070	2000	3-6	3800	4100			
	TFM650	6500	600	1100	550	1200	2845	7107	2500	2500	3-6	3850	4150			
	TFM700	7000	100	700	150	800	3045	7607	3000	2935	3-6	3900	4200			

Note: 1. With side shifter, load capacity subtract 200KG.
2. * (Asterisk) is for double front wheels model.

3.0-3.5 TON MAST SPECIFICATIONS & RATED CAPACITIES

Mast Type	Mast Name	Max.Fork Height (mm)	Load Capacity (KG)				Overall Height (mm)			Free Lift (mm)		Tilt Angle (Single)	Tilt Angle (Double)	Total Weight (KG)		
			FB30	FB30	FB35	FB35	Lowered	Extended	Without Backrest	With Backrest	3.0/3.5t			3.0/3.5t	FB30	FB35
			Without Backrest		With Backrest		Without Backrest		With Backrest							
Wide View Mast	M200	2000	3000	3000	3500	1570	2690	3170	100	100	6-12	4260	4760			
	M250	2500	3000	3000	3500	1820	3190	3670	100	100	6-12	4300	4800			
	M270	2700	3000	3000	3500	1920	3290	3770	145/150	145/150	6-12	4314	4814			
	M290	2900	3000	3000	3500	2020	3490	4070	145/150	145/150	6-12	4332	4832			
	M300	3000	3000	3000	3500	2070	3590	4070	145/150	145/150	6-12	4340	4840			
	M310	3100	3000	3000	3500	2120	3790	4270	145/150	145/150	6-12	4350	4850			
	M330	3300	3000	3000	3500	2220	3890	4370	145/150	145/150	6-12	4365	4865			
	M350	3500	3000	3000	3500	2320	4090	4570	145/150	145/150	6-12	4380	4880			
	M400	4000	2950	3250	3550	2620	4590	4890	145/150	145/150	6-6	4420	4720			
	M430	4300	2800	2900	3100	2770	4890	5370	145/150	145/150	6-6	4445	4745			
2-Stage Full Free View Mast	M450	4500	2800	2800	2800	2870	5090	5770	145/150	145/150	6-6	4460	4760			
	M470	4700	2500	2800	2900	2970	5290	5770	145/150	145/150	6-6	4475	4765			
	M500	5000	2200	2550	2400	2800	3170	5590	6070	145/150	145/150	6-6	4510	4810		
	M550	5500	2000	2400	2300	2690	3370	5990	6570	145/150	145/150	3-6	4560	4860		
	M600	6000	1500	2000	1600	2400	3670	6990	7070	145/150	145/150	3-6	4600	4900		
	FM200	2000	3000	3000	3500	1570	2590	3065	882	407	6-12	4340	4840			
	FM250	2500	3000	3000	3500	1820	3090	3565	970	470	6-12	4360	4860			
	FM270	2700	3000	3000	3500	1920	3240	3715	1232	757	6-12	4395	4895			
	FM290	2900	3000	3000	3500	2020	3440	3915	1332	857	6-12	4410	4910			
	FM300	3000	3000	3000	3500	2070	3590	4065	1382	907	6-12	4420	4720			
3-Stage Full Free View Mast	FM310	3100	3000	3000	3500	2120	3740	4215	1432	957	6-12	4430	4850			
	FM330	3300	3000	3000	3500	2220	3940	4415	1532	1057	6-12	4445	4745			
	FM350	3500	3000	3000	3500	2320	4140	4615	1632	1157	6-12	4460	4760			
	FM370	3700	3000	3000	3400	2420	4340	4715	1732	1257	6-6	4475	4775			
	FM400	4000	2950	3250	3550	2620	4890	5065	1982	1507	6-6	4500	4800			
	TFM400	4000	3000	3000	3000	1960	4700	5175	1272	797	6-6	4550	4850			
	TFM430	4300	2800	2900	3000	2060	4900	5475	1372	897	6-6	4580	4880			
	TFM450	4500	2600	2800	2800	2110	5000	5675	1422	947	6-6	4600	4900			
	TFM470	4700	2400	2700	2500	2160	5100	5875	1472	997	6-6	4620	4920			
	TFM500	5000	2100	2400	2300	2060	5200	6175	1572	1097	6-6	4630	4850			

Note: 1. With side shifter, load capacity subtract 200KG.
2. * (Asterisk) is for double front wheels model.

